

Mobiles

Freestanding



Unique Mobile Communications Solutions

Featuring:

- Egan GlassWrite™ Panels
- Egan Screen Door
- EganINK™ letters, lines, graphics
- Guaranteed-to-clean
- Dust-free dry-erase

Egan GlassWrite Mobiles

Dry-erasable, translucent privacy

Crystal clear or translucent Egan GlassWrite Mobiles are the hot solution when glass is part of your specification. Built on Egan's V-Series mobile platform (page 4) with tempered glass inserts and a design or pattern of your creation. Create grids to assist in lettering, maps to locate opportunities, brand enhancing visuals or exciting environmental imagery. EganINK—durable letters/lines/graphics is an Egan exclusive innovation offering colorful high resolution graphics.



V-Series Mobile with Egan GlassWrite translucent tempered glass panel
VSF3054G with "Grid Dots"



V-Series Mobile with Egan GlassWrite crystal clear tempered glass panel and tackable fabric lower panel

VCF3060G with "Gapped Grid"

V-Series Mobile with Egan GlassWrite tempered glass panel

VSF3060G with "Bamboo Bloom"



Brilliant ideas

Egan V-Series mobiles are available with tempered GlassWrite Panels suitable for shared or two-sided annotations. Tackable fabric lower panels increase the design options for this versatile mobile solution.

Let the light shine in

Stimulate the environment

Playful photographs or colorful accents can really add tremendous value to any interior design situation. Egan GlassWrite mobiles move about the room as needed to provide signage, message boards, meeting tools or simply add a smile. Available widths: 30", 36" and 48". Available heights: 54", 60", and 66".

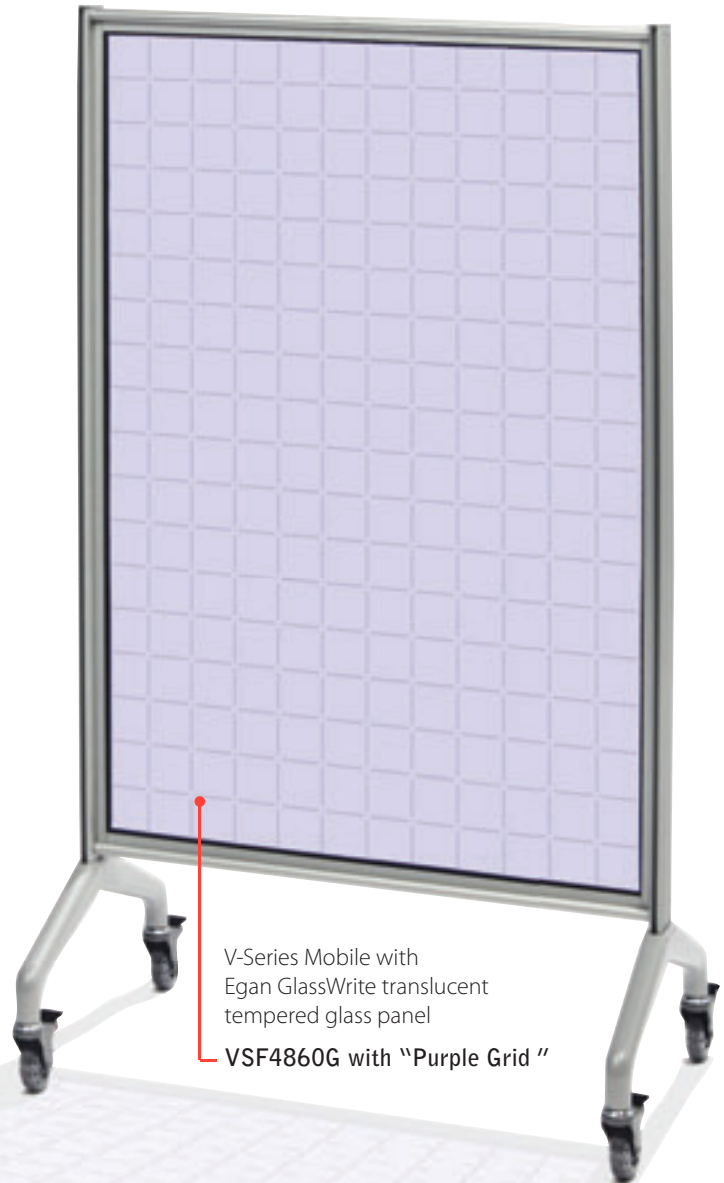

Custom by design

Create privacy partitions on the fly while maintaining the natural light of the area. Teams can form intimate areas without losing touch with the rest of the office. The translucent quality of Egan GlassWrite helps to make objects more than a foot away indistinguishable, while dry-erase notes are clearly legible from both sides.

V-Series Mobiles

Linkable partitions, large format, lots of design options

V-Series Mobiles are space dividers and partitions that can nest together. Options include guaranteed-to-clean Egan VersaSurface dry-erase that accepts magnetic accessories and Maharam tackable fabric. Offered in full height or split height panels with sturdy EganMetallic bases.

Available widths:
30", 36", 48", 60"

Available heights:
54", 60", 66", 72"



Ensemble of V-Series Split Panel Mobiles

Egan VersaSurface on both sides, lower panel is Maharam Grade "C" tackable fabric

Single panel, 4-point base, Egan VersaSurface on both sides, shown with available accessories

VSF3054EE



Great for Projection



Veneer Insert



Grass Pattern Insert



Glass Insert



Acrylic Insert



Customer's Own Panel

Accessory grooves located in the uprights provide easy addition of an Egan Accessory Shelf (illustrated top-right). Frames can be specified with custom color.

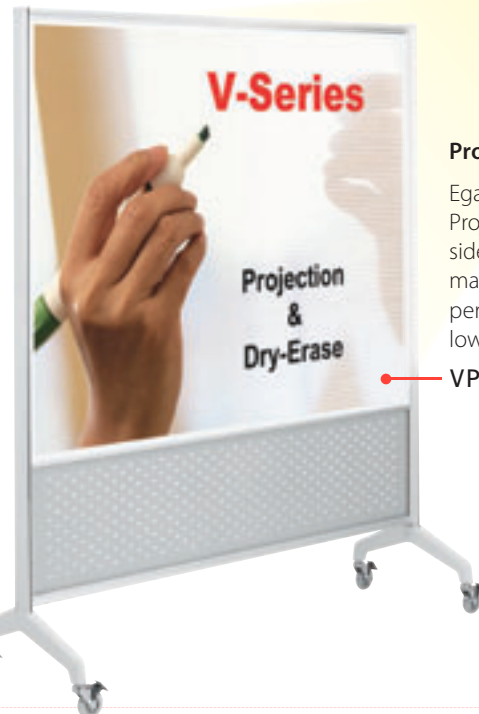

Projection mobile

Egan VersaSurface Projection on both sides, split height to match projection ratio, perforated metal lower panel

VPF6072EE

Egan Screen Door

Control traffic, create privacy, easily

Working in teams makes sense, managing workspace for teams and individuals requires flexibility.

Egan Screen Doors control traffic and provide privacy, offering creative functionality and an array of appealing design options. Egan Screen Door is based on the Egan Lite Mobile platform (page 6) and may also be specified in custom widths in volume orders.

Egan Screen Door has the flexibility to fit into any office panel system installation.

Universal fit trip-free 360° rotating base. Available in 54" or 60" heights, 36", 42" and 48" widths, and custom widths in volume orders. Guaranteed-to-clean Egan VersaSurface dry-erase surface and thousands of fabric options to integrate with all panel system passage ways.

Door swings on a low-resistance spherical caster. Optional perforated steel lower panel at a standard 24"h permits air circulation.

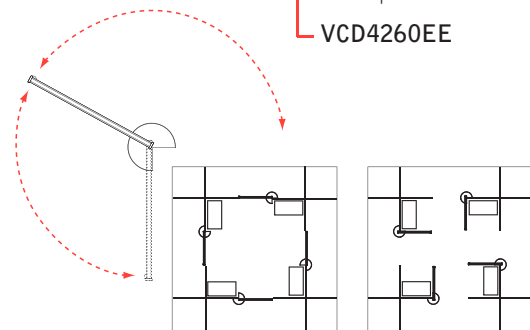

42" w x 60" h, tackable fabric 2 sides, lower perforated steel panel. Custom built to match customer's existing installation and interior design



VCD4260FF

Team Privacy

Individual Privacy

Egan Screen Door swings to redirect traffic. Fold away or close to create privacy

Egan Lite Mobiles

Lightweight mobile partitioning

Incredibly lightweight and easy to move, Egan Lite Mobiles are offered with low profile trip-free bases or locking casters to suit your application. Surface options include guaranteed-to-clean Egan VersaSurface, natural cork, and a variety of Maharam tackable fabric options to provide design possibilities. Frames may be specified with custom color.

Available widths:
30", 36", 42"

Available heights:
54", 60", 66"

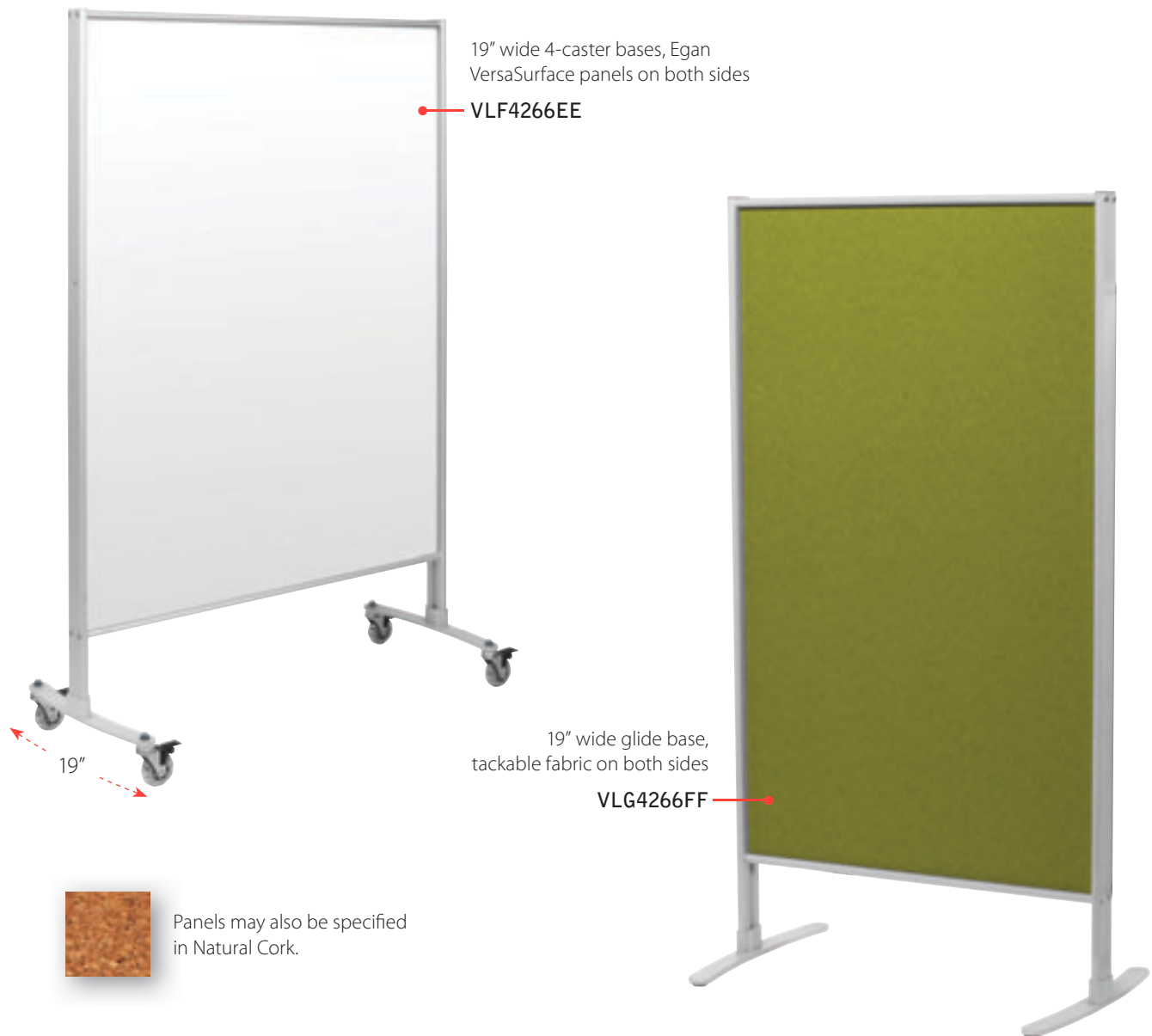

A-Frame VersaMobiles

Dry-erase presentation powerhouse

Ideal for mobile presentations, the spacious 74" h A-Frame VersaMobile offers a shelf cavity for storage of up to five boards. Available with two-sides of high-performance surfaces. Specify any combination of guaranteed-to-clean Egan VersaSurface or tackable fabric. A fixed track at the top of the A-Frame mounts EganSystem Track compatible boards.

Available widths:
30", 36", 42", 48"

Available height:
74" only

