



OVO™ LECTERNS

OVO™ LECTERNS





OVO™ LECTERNS

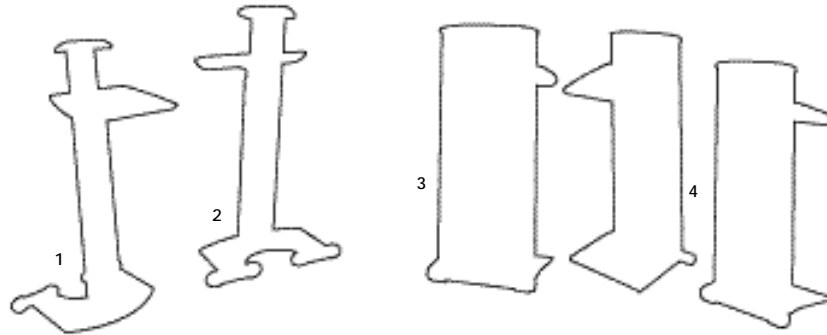

- | | |
|--|--|
| <p>1 OVL-1
Fixed Document Platform 37" h
50" h x 22" w x 21" d
Optional light and clock/timer</p> <p>2 OVL-2
Adjustable Document Platform 37"-42" h
50" h x 22" w x 21" d
Optional light and clock/timer</p> | <p>3 OVL-3
Fixed Document Platform 37" h
48" h x 22" w x 21" d
Optional light and clock/timer</p> <p>4 OVL-4
Adjustable Document Platform 37"-42" h
48" h x 22" w x 21" d
Optional light and clock/timer</p> |
|--|--|



Egan Visual, Inc.
USEast and Canada

905-851-2826 1-800-263-2387
Fax 1-888-609-8886 evi@egan.com

Egan Visual/West, Inc.
Western States

323-720-1336 1-800-826-1778
Fax 1-800-726-1314 evw@egan.com